

CO2-Humidity-Temp Transmitter w/ Bacnet

Description

The CO2 sensor with Humidity & Temp transmitters are designed for environmental monitoring and controlling in industrial, commercial and other buildings. These transmitters can be used for indoor CO2, temperature and humidity monitoring. The modbus interface provides easy setup and integration into large systems.



Highlights

- High performance sensing elements, temperature compensated, stable
- RS485 for direct digital reading on all models, Ethernet option available for Duct/Wall types
- Easy troubleshooting with pluggable sensors and backplate
- Transducer outputs are jumper selectable: 4-20mA, 0-5V or 0-10V
- LCD display with backlight on all models
- Automatic background calibration, default CO2 value: 40000 ppm
- Enthalpy, its calculated automatically and available in the register list and display

Specifications

Sensing	CO2		HUM		TEMP	
	Conditions	Value	Conditions	Value	Conditions	Value
Range	–	0 – 40'000 ppm	–	0 %RH – 95 %RH	–	- 20°C – 60°C
Accuracy	0 ppm – 5'000 ppm	± (30 ppm + 3%MV)	25°C, 0 – 95 %RH	± 5 %RH	0 – 50°C	± (0.5°C + 0.023 × (T [°C] – 25°C))
Repeatability	0 ppm – 5'000 ppm	± 10 ppm	–	± 0.1%RH	–	± 0.1°C
Response time	τ63%	60 s	τ63%	> 90 s	τ63%	> 60 s
Accuracy drift over lifetime	400 ppm – 5'000 ppm ASC field-calibration algorithm activated and SCD40 in environment allowing for ASC, or FRC field-calibration algorithm applied.	± 50 ppm	–	< 0.25 %RH / year	–	< 0.03 °C / year

1 Default conditions of T = 25°C, humidity = 50 %RH, p = 1013 mbar.

2 Deviation to a high-precision reference. Accuracy is fulfilled by > 90% of the sensors after calibration. Rough handling, shipping and soldering reduces the accuracy of the sensor. Full accuracy is restored with FRC or ASC recalibration features. Accuracy is based on tests with gas mixtures having a tolerance of ± 1.5%.

3 RMS error of consecutive measurements at constant conditions. Repeatability is fulfilled by > 90% of the sensors.

4 Time for achieving 63% of a respective step function. Response time depends on the operating mode, design-in and environment of the sensor in the final application. The specified response time represents ideal design-in situation and high performance mode operation.CO2 concentration 400 ppm regularly.

5 CO2 concentrations < 400 ppm may result in sensor drifts when ASC is activated. For proper function of ASC field-calibration algorithm SCD40 has to be exposed to air with CO2 concentration 400 ppm regularly.

CO2-Humidity-Temp Transmitter w/ Bacnet

6 Design-in of the SCD40 in final application and the environment impacts the accuracy of the RH/T sensor. Heat sources have to be considered for optimal performance.

Please use integrated on-board RH/T compensation algorithm to account for the actual design-in.

7 Deviation to a high-precision reference. Accuracy is fulfilled by > 90% of the sensors after calibration.

8 RH/T sensor component is capable of measuring up to T = 120°C. However, measuring at T > 70°C might result in permanent damage of the sensor module.

Note:

1. The default setting for the transducers is 0 to 10V, over the range 0 to 100 Degrees C. If you're using the 10V transducer output signal, the sensor needs to be powered with at least 15V AC or DC.
2. For application not using the 10V transducer output signal, using 4-20ma signal, 0-5V transducers, or Modbus/Ethernet only, in this case you can use 12V AC or DC.

Dimensions

CO2-D1 & CO2-W1

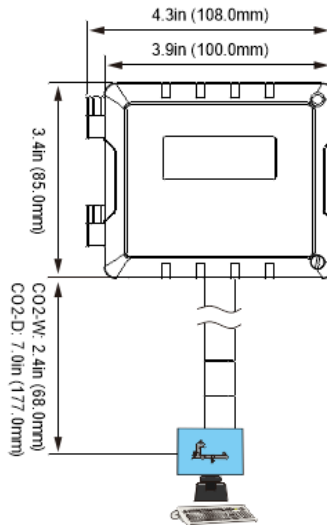
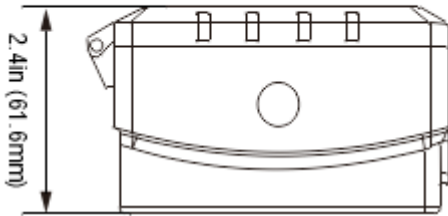

Part Number Scheme

CO2 - D1

Code	Description
CO2	CO2 Sensor

Code	Module
D1	Duct Mount
W1	Wall Mount
C1	2 Meter Cable

Wiring Diagram

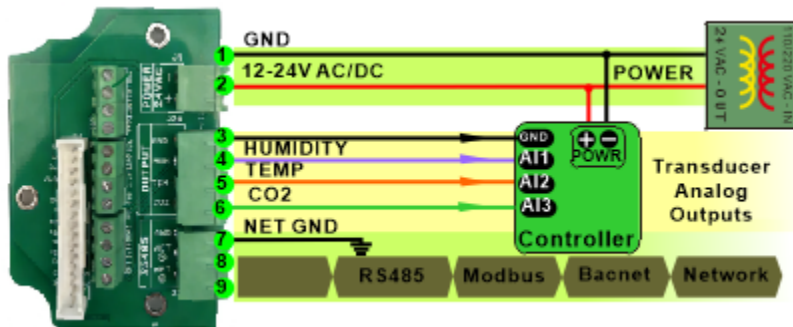

CO2-Humidity-Temp Transmitter w/ Bacnet

The diagram below shows the wiring connection for the usual transducer mode of operation for the CO2-D1 duct mount and CO2-W1 wall mount style sensors. The transducer outputs connect to a master controller using traditional analog output signals. The RS485 network is available for transmitting the same values digitally to other controllers in the system by connecting to the RS485 network at Pins 8 and 9.

Output Jumper settings

In this mode the device acts as a traditional transducer where it sends out three analog signals, all you need to do is to set this one single jumper to the appropriate signal type: 4-20mA, 0-10V, or 0-5V.

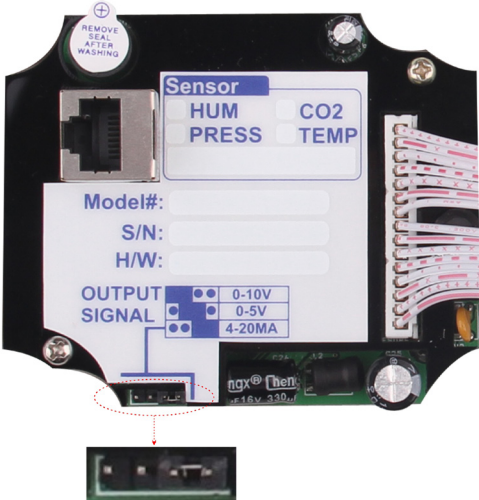

CO2-Humidity-Temp Transmitter w/ Bacnet

Modbus Register List

CO2-Humidity-Temp Transmitter w/Bacnet uses MODBUS protocol to communicate with others. Below is the Modbus register list.

Address	Bytes	Register Description
1...2	2	Lower 2 bytes of the serial number
2..3	2	Upper 2 bytes of the serial number
4	1	firmware version lower byte. eg. FW version=10.12, so lower byte=12AND high byte=10. Fixed.
5	1	firmware version upper byte. eg. FW version=10.12, so lower byte=12AND high byte=10. Fixed.
6	1	Modbus device address default:254
7	1	Product ID,Fixed
8	1	Hardware version
9	1	spare
10	1	spare
14	1	sensor type,Bit0=co2,Bit1=Hum,Bit2=Temp, Bit3=Pressure
15	1	Baudrate Setting:0=9600bps,1=19200bps,2=38400bps,3=57600bps,4=115200bps,default:11.5kbaud
16	1	Firmware Update Register,used to show the status of firmware updates
21	1	Protocol switch.3=MODBUS,0=MSTP. Default:Modbus
17....39	23	spare
40 to 45	6	reg40,MAC,address,read only normally
46	1	reg46,IP mode 0=static IP; 1=DHCP default:static
47 to 48	2	reg47,upper two bytes of IP address default:192.168
49 to 50	2	reg49, upper two bytes of IP address default:0.34
51 to 52	2	reg51,right two bytes of SUBNET MASK address
53 to 54	2	reg53,left two bytes of SUBNET MASK address
55 to 56	2	reg55,right two bytes of GATEWAY address
57 to 58	2	reg57,left two bytes of GATEWAY address
59	1	reg59,0,TCP server,(NO USE)
60	1	reg60,listen port at TCP server mode
61~75		buffer mirror for changing to a new IP address,copy of reg 46 to 60
76	1	write 1 to set the ghost setting to the system and start new settings, then clear the ghost registers
93	1	Enable for MAC setting.It should be set as 1 before write the new MAC to the MACregisters(100-105),and it will be cleared automatically after setting the MAC address
94...199	7	Reserved for future
200	1	Temperature sensor selection,0=external,1=internal.Read only,it will be set to 1 if the humidity module exists

CO2-Humidity-Temp Transmitter w/ Bacnet

Address	Bytes	Register Description
201	1	Select the unit of temperature to display on LCD.0=degree Celsius.1=degree Fahrenheit
202	1	The value of on board temperature sensor,the unit is degree Celsius.The resolution is 0.1 degree
203	1	The value of on board temperature sensor,the unit is degree Fahrenheit.The resolution is 0.1 degree
204	2	The value of external temperature sensor,the unit is degree Celsius.The resolution is 0.1 degree
205	2	The value of external temperature sensor,the unit is degree Fahrenheit.The resolution is 0.1 degree
206	2	The temperature offset for calibrating the internal temperature.The resolution is 0.1degree
207	2	Relative humidity.The resolution is 0.1%
208	2	Read only.The real frequency read from the humidity module,unuse
209	1	Read only.The number of the calibration table points.
210	1	Internal CO2 sensor selection.The value is 1 as default.1=MAYBE_OGM200;2=MAYBE_TEMCO_CO2;3=OGM200;4=TEMCO_CO2
211	2	The CO2 ppm value of internal CO2 sensor
212	2	The CO2 ppm offset for calibrating internal CO2 sensor
213	2	The setpoint value of fair alarm for internal CO2 sensor
214	2	The setpoint poor of fair alarm for internal CO2 sensor
215..468	2*254	The CO2 ppm value of the external CO2 sensors if there are/is CO2 nodes connect to it
469..722	2*254	The CO2 ppm offset for calibrating external CO2 sensor
723..976	2*254	The setpoint value of fair alarm for external CO2 sensor
977..1230	2*254	The setpoint value of poor alarm for external CO2 sensor
1231	2	reserve
1232	1	The filter of CO2 sensor
1234	1	Enable/Disable the password for the menu system operation.0=Disable 1=Enable
1235	1	The second digital of the password.Should be from 0 to 9
1236	1	The third digital of the password.Should be from 0 to 9
1237	1	The fourth digital of the password.Should be from 0 to 9
1238	1	The century of the real time clock
1239	1	The year of the real time clock
1240	1	The month of the real time clock
1241	1	The date of the real time clock
1242	1	The weekday of the real time clock
1243	1	The hour of the real time clock
1244	1	The minute of the real time clock

CO2-Humidity-Temp Transmitter w/ Bacnet

Address	Bytes	Register Description
1245	1	The second of the real time clock
1246	1	Alarm auto/manual control.Bit7: 0=auto,1=manual;1=pre_alarm;bit1:1=continuous_alarm;bit(1:0):00 =stop_alarm
1247	1	The alarm output turn on time,<=20 seconds.
1248	1	The alarm output turn off time,<=20 seconds.
1249	1	Alarm output delay time.It delays the alarm output when the alarm is triggered.It is 5 seconds as default.
1250	1	Analog output auto/manual control.Bit 0 directs to temperature output, Bit 1 directs to humidity output,Bit 2 directs to CO2 output.0=Auto,1=Manual.
1251	2	The manual value of temperature
1252	2	The manual value of humidity
1253	2	The manual value of CO2
1254	1	Analog output mode,read only,select by jumper.1=0-10V,2=0-5V,3=4-20mA
1255	2	The lowest value of temperature for analog output
1256	2	The Highest value of temperature for analog output
1257	2	The Lowest value of humidity for analog output
1258	2	The Highest value of humidity for analog output
1259	2	The lowest value of CO2 for analog output
1260	2	The Highest value of CO2 for analog output
1261	1	Reserve
1262	1	The period for the LCD backlight keep on.The backlight turns on when key is triggered and turns off the it expires.
1263	1	Enable/Disable the plug-play feature of the external nodes.0=disable 1=enable
1264	1	The number of CO2 sensors connect to the unit. includes the internal CO2 sensor
1265	1	Set 1 to reset the scan table
1266..1270	1*5	The first CO2 node sensors information.Normally it is the unit itself register 1266:the modbus ID of the CO2 sensor register1267..1270:the serial number of the CO2 sensor
1271..1275	1*5	The second CO2 node information.Normally,it is the first external CO2 node
1276..1280	1*5	The third CO2 node information.
...		
...		
2531..2535	1*5	The 254th CO2 node information
3000	1	The internal temperature filter
3001	1	The external temperature filter
3002	1	The humidity filter
3003	1	The humidity sensor version

CO2-Humidity-Temp Transmitter w/ Bacnet

Address	Bytes	Register Description
3004	2	The humidity sensor serial number
3005	1	The humidity sensor factory calibrate point number
3006	1	The humidity sensor calibrate table select 0=factory 1=user table
3007..3026	2*254	factory calibrate table.Register3007:The 1st Calibrate point,Frequency,Register3029: The 1st Calibration point.Frequency
3027	1	user calibration table point number
3028..3047	2*254	user calibrate table. Register3028:The 1st Calibrate point RH,Frequency,Register3029: The 1st Calibration point.Frequency
3049	2	The dew point.In degree C
3050	2	The dew point . In degree F
3051	2	The Lowest value of dew point for analog output
3052	2	The heighest value of dew point for analog output
3053	2	Partial pressure of water at saturation at given temperature [hPa]
3054	2	Mixing Ratio,the mass of water over the mass of dry gas[g/kg]
3055	2	Enthalpy of the air,[KJ/kg]
3056	2	The external temperature offset
3057	2	The user table humidity offset
3058	2	The default table humidity offset
3066	2	The analog output value of humidity(0.01ma/0.01v)
3067	2	The analog output value of temperature
3068	2	The analog output value of CO2

CO2-Humidity-Temp Transmitter w/ Bacnet

Bacnet

CO2-Humidity-Temp Transmitter w/Bacnet uses Bacnet protocol to communicate with others. Below is the Bacnet register list.

Backed Object	Variable and Description
Variable1	Serial Number Low Byte
Variable2	Serial Number High Byte
Variable3	SoftWare Version
Variable4	Device ID
Variable5	Product Model
Variable6	Instance
Variable7	Station number
Variable8	Uart BaudRate.0=9.6kbaud,1=19.2kbaud 2=38.4kbaud 3=57.6kbaud 4=115.2kbaud
Variable9	Update
Variable10	Protocol
Variable11	Auto/Manual
Variable12	Dew point
Variable13	Pws
Variable14	Lowest ratio
Variable15	Enthalpy
Variable16	OffSet CO2
Variable17	Filter Temperature
Variable18	OffSet CO2
Variable22	Filter Humidity
Variable23	Filter Temperature
Variable24	Filter CO2
Variable28	Temperature Unit.0=C,1=F
Variable29	OutMode.1=0-10v,2=0-5v,3=4-20mA
Variable30	Output1 Lowest Range
Variable31	Output1 Highest Range
Variable32	Output2 Lowest Range
Variable33	Output2 Highest Range
Variable34	Output3 Lowest Range
Variable35	Output3 Highest Range

CO2-Humidity-Temp Transmitter w/ Bacnet

	Input and Description
Input1	Temperature
Input2	Humidity
Input3	CO2

	Output and Description
Output1	Humidity/Analog output
Output2	Temperature Analog output
Output3	CO2 Analog output

CO2-Humidity-Temp Transmitter w/ Bacnet

Voltage & Current Formula

The max and min value are the range max and min value, the range can be set by the customer.

Default Temperature Range: 0-1000 (0-100.0C)

Default Humidity Range: 0-1000 (0-100.0% rH)

Default CO2 Range: 0-3000ppm

Also the temperature, humidity, CO2 range value can be set by T3000 software, here follow the screen shot from T3000.

The output default range can be set here.

NUM	Full Label	Value	Range	Min Out Scale	Max Out Scale	Unit
1	Hum	9.38	4-20mA	0.0	100.0	%
2	Temperture	0.42	4-20mA	0.0	100.0	°C
3	CO2	8.67	4-20mA	0	2000	ppm

CO2-Humidity-Temp Transmitter w/ Bacnet

Formula for Analog Outputs	
0-10V Output	Temperature(C)=[Voltage * (High_T - Low_T) + 10 * Low_T] /100
	Temperature(F)=(DegC)*9/5+32
	Humidity=[Voltage * (High_H - Low_H)+10 * Low_H]/100
	CO2=Voltage * (High_C-Low_C)/10+Low
0-5V Output	Temperature(C)=[Voltage * (High_T - Low_T) + 5 * Low_T] /50
	Temperature(F)=(DegC)*9/5+32
	Humidity=[Voltage * (High_H - Low_H) + 5 * Low_H]/50
	CO2=Voltage * (High_C - Low_C)/5+Low_C
4-20mA	Temperature(C)=(Current-4) * (High_T - Low_T) + Low_T/10
	Temperature(F)=(DegC)*9/5+32
	Humidity=(Current-4) x (High_H - Low_H) + Low_H/10
	CO2=(Current-4) x (High_C - Low_C)/16 + Low_C

Register List

CO2-D1, CO2-W1 without network	High_T=R286 High_H=R288 High_C=R290 Low_T=R285 Low_H=R287 Low_C=R289
CO2-D1, CO2-W 1with network	High_T=R1256 High_H=R1258 High_C=R1260 Low_T=R1254 Low_H=R1257 Low_C=R1259

For example

1. Product: CO2-D1
2. Output range: 0-10V output (Adjust jumper to select 0-10V in PCB board)
3. The default settings R285 = 0 and R286 = 1000, that means the default output scale is 0C-100.0C, and they can be set by customer.
4. Measuring temperature output voltage: 7.8V
5. Temperature(C)=[Voltage * (High_T - Low_T) + 10 * Low_T] /100

$$= [7.8 * (1000-0) + 10 * 0] / 100$$

$$= 78C$$

CO2-Humidity-Temp Transmitter w/ Bacnet

Instrument Operation

7.1) There are four keys. The first and second keys are used to increase and decrease the value and select the up down list. When click the third key, it will be back to the previous view layer. And click the forth key, it will switch to the next item.



Increase value or select up list



Decrease value or select down list



Back or return



Next or confirm



Menu display chart



The following value was taken as an example so you can understand it well.

CO2	Zone 0: Zone 254:	1. Delete node 2. Spt poor: 2500 3. Spt fair: 2500 4. Calibration: 1294
Temperature	1. Int: 23.0°C 2. Ext: 18.2°C 3. Unit: °C/ °F 4. Sensor disp.: Ext./Int.	
Humidity	1. Calibration: 34.9% 2. Heat: ON/OFF	
Miscellaneous	1. Modus ID: 251 2. Date: 2014-12-17 3. Time: 11:00 4. Ring on time: 2 5. Ring off time: 2 6. Baudrate: 19200 7. Factory reset 8. Use password: Yes/No 9. Password	





CO2-Humidity-Temp Transmitter w/ Bacnet

a. Normal state:

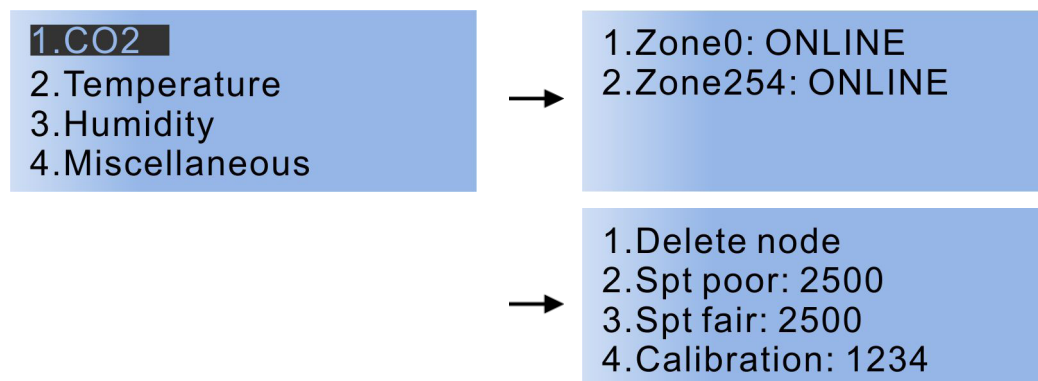



Zone0: 37.4% 17.0°C
1149 ppm
2014-12-17 11:00 NET

b. Please press , it will switch to menu view as the following picture shows. Continue to press  and it will go into the CO2 list. Press  again, into the zone0's list.

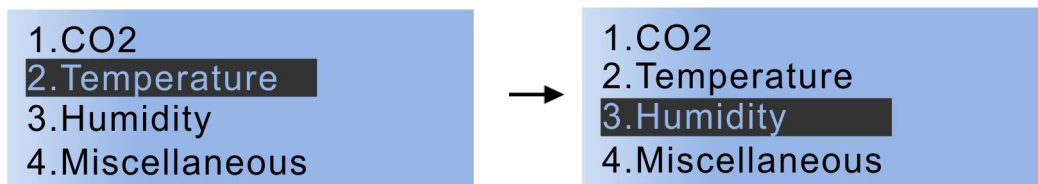





c. Please press , come back to the menu column. Press  or , and select Temperature, then press , go into the temperature list.

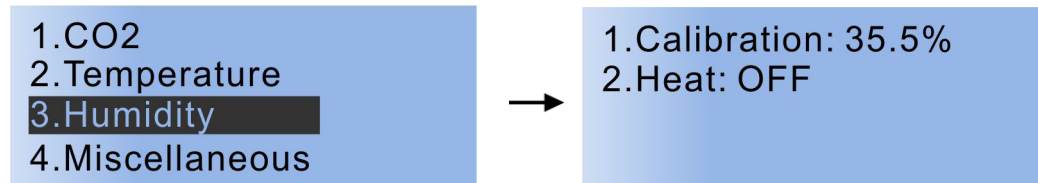

d. Please press , come back to the menu column. Press  or , and select Humidity, while press , go into the humidity list.





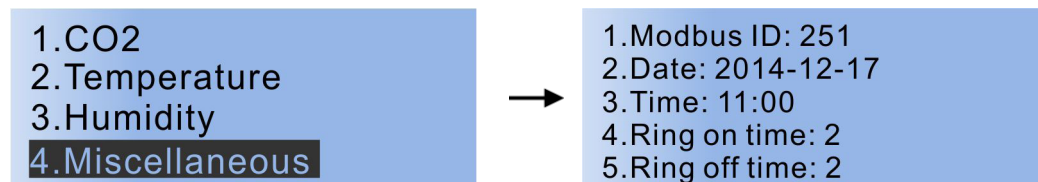

e. Please press , come back to the menu column. Press  or , and select Miscellaneous, continue to press , go into the miscellaneous list.



f. When everything is set, after a while, it will switch to the normal state as step as displayed.

CO2-Humidity-Temp Transmitter w/ Bacnet

Modbus/Bacnet switch

To select the protocol as Modbus or Bacnet, Press  to choose Miscellaneous, then press  to choose Protocol switch, press , it reads Mstp, which means you have selected Bacnet ;if you want to switch to Modbus, press , or  back to Bacnet.

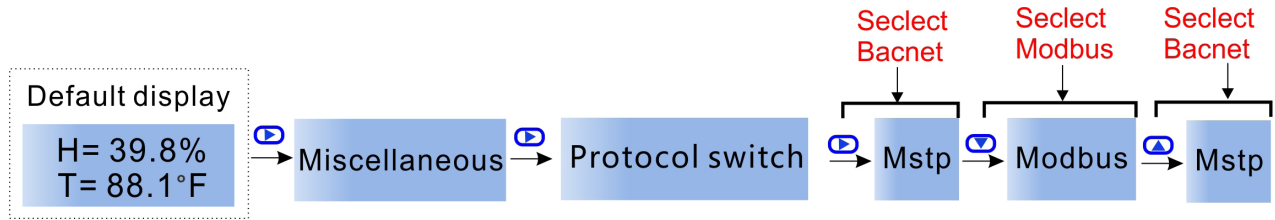

Or you can check the Bacnet Resgister List, No.9: Protocol switch. 0 = MODBUS, 1=MSTP.

Mounting Installation

1) Slotted screwdriver.

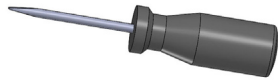

Captive screw (slotted screw)



2) Unfasten screw at cover, turn the captive screw 1/2 turn till it pops out.

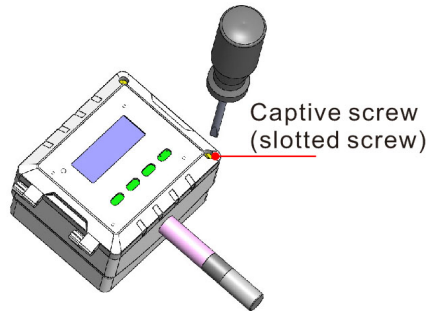

3) Open the cover.

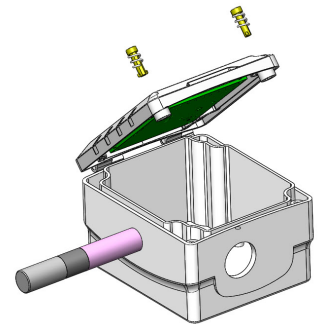

4) There are three small holes as red arrows showed below inside the box for fastening self tapping screws drilling the hole in the duct with a template

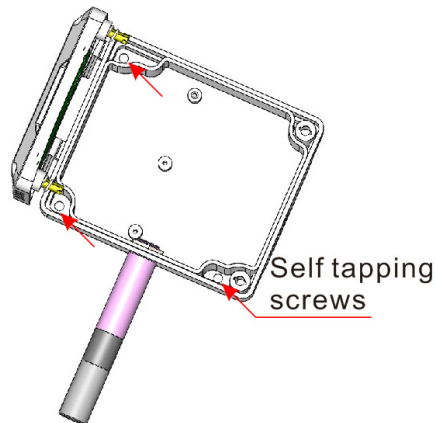

5) Re-fasten screw at cover.

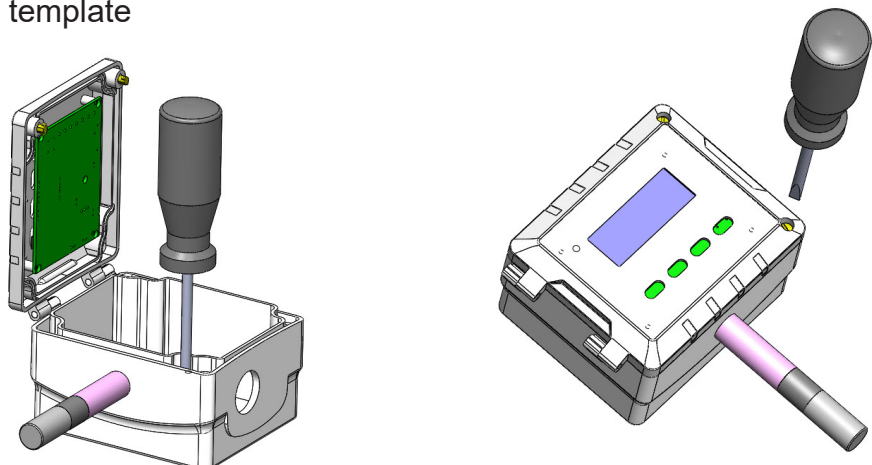

CO2-Humidity-Temp Transmitter w/ Bacnet

Accessories

CO2-W1



This new Transmitter brings with it the incorporation of CO2 Monitoring. When the External CO2 Sensor is attached, the transmitter can process and display detailed information about the current CO2 count.

You can set the alarm setpoints in the menu using buttons or RS485. There are two alarm setpoints:

1. Fair alarm: the alarm output will be turned on for the ALARM_ON seconds, then be turned off for ALARM_OFF seconds, and go on on-off-on-off .
2. Poor alarm: the alarm output will be turned and kept it on.

AND there are two types of the CO2-W we have, one with ethernet and the other without ethernet.

- 1)ALARM_ON, you can set it in the register1247 with ethernet or register152 without ethernet.
- 2)ALARM_OFF, you can set it in the register1248 with ethernet or register153 without ethernet.
- 3)Fair setpoint you can set it in the register213 with ethernet or register 155 without ethernet.
- 4)Poor setpoint you can set it in the register214 with ethernet or register156 without ethernet.

CO2-Humidity-Temp Transmitter w/ Bacnet

CO2-D1/W1 in T3000 Operation

1). Connect CO2 to PC by RS485 and start T3000 software.

2). Click the button  to scan, the following view will appear and close it as the picture indicates.

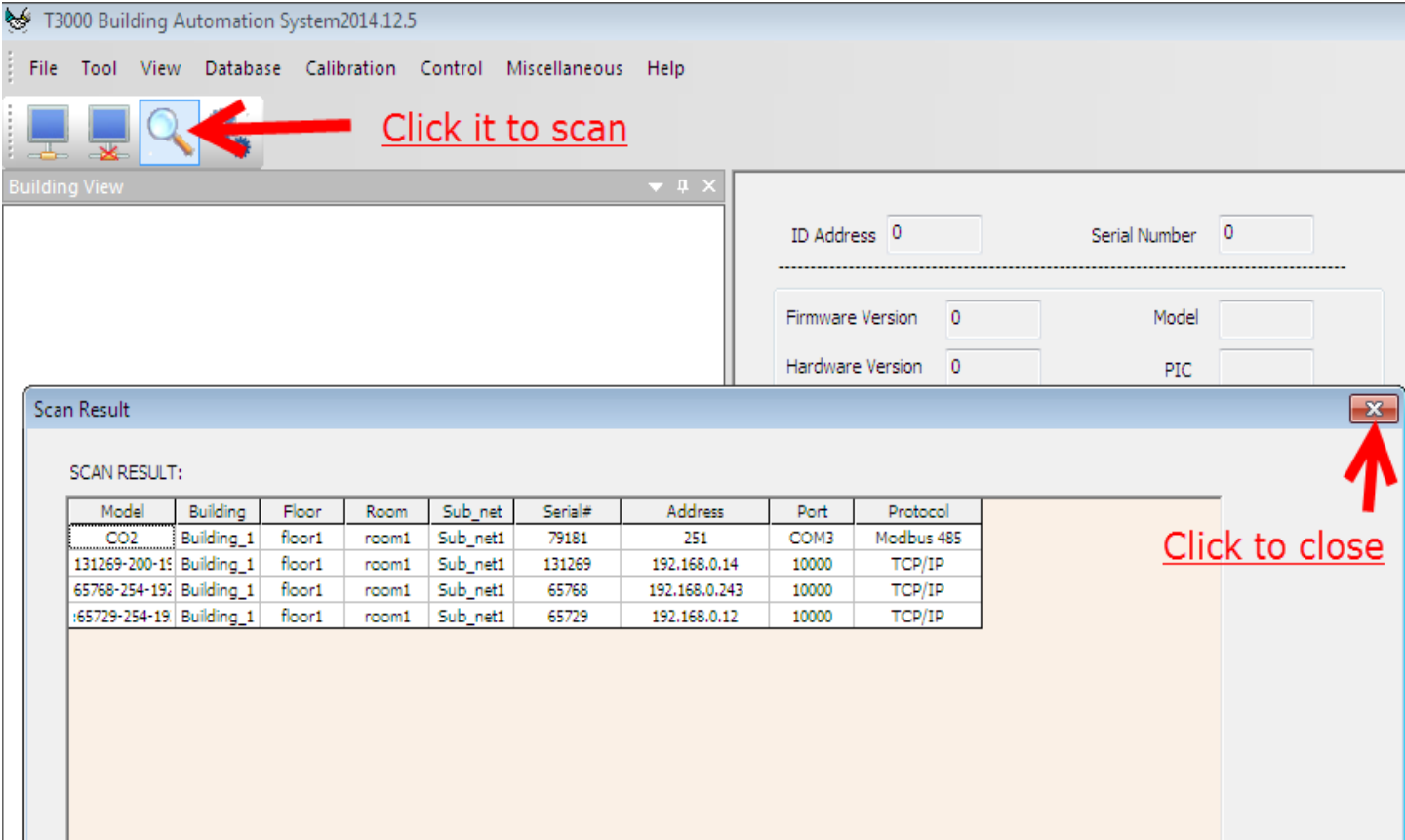

The screenshot shows the T3000 Building Automation System interface. The main window has a menu bar (File, Tool, View, Database, Calibration, Control, Miscellaneous, Help) and a toolbar with icons for various functions. A red arrow points to the scan button (magnifying glass icon) with the text "Click it to scan". Below the toolbar is the "Building View" section, which includes input fields for ID Address (0), Serial Number (0), Firmware Version (0), Model, Hardware Version (0), and PIC. A "Scan Result" dialog box is open in the foreground, displaying a table of scan results. A red arrow points to the close button (X icon) in the top right corner of the dialog box with the text "Click to close".

Model	Building	Floor	Room	Sub_net	Serial#	Address	Port	Protocol
CO2	Building_1	floor1	room1	Sub_net1	79181	251	COM3	Modbus 485
131269-200-19	Building_1	floor1	room1	Sub_net1	131269	192.168.0.14	10000	TCP/IP
65768-254-19	Building_1	floor1	room1	Sub_net1	65768	192.168.0.243	10000	TCP/IP
65729-254-19	Building_1	floor1	room1	Sub_net1	65729	192.168.0.12	10000	TCP/IP

CO2-Humidity-Temp Transmitter w/ Bacnet

3). Click CO2 log  **CO2:79181--251** and the T3000 will show all the information of CO2.

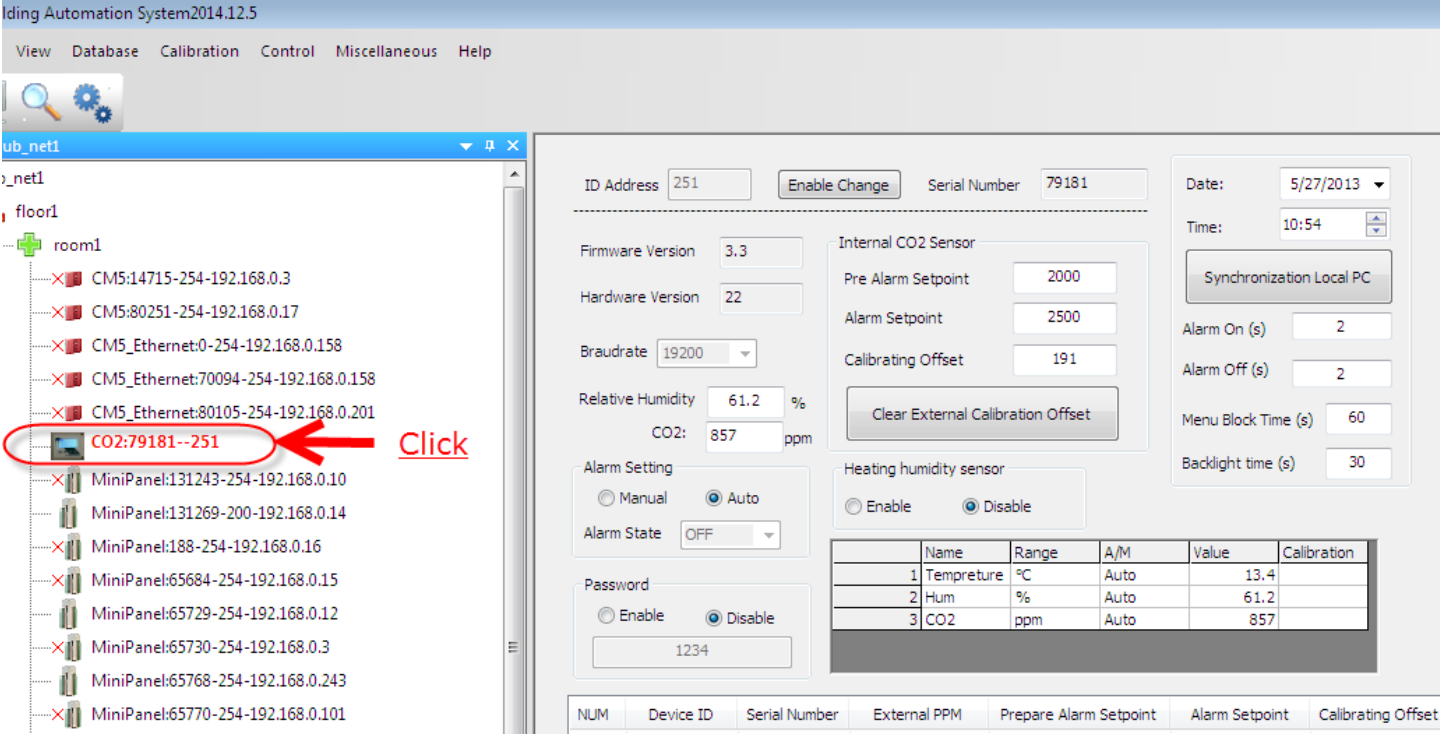

The screenshot shows the 'Building Automation System 2014.12.5' interface. On the left, a tree view shows a hierarchy: 'ub_net1' > 'floor1' > 'room1'. Under 'room1', several devices are listed, including 'CM5' and 'MiniPanel' units. The device 'CO2:79181--251' is highlighted with a red circle, and a red arrow points to it with the text 'Click'.

The main configuration panel for 'CO2:79181--251' is displayed on the right. It includes the following fields and controls:

- ID Address: 251 (with 'Enable Change' button)
- Serial Number: 79181
- Date: 5/27/2013
- Time: 10:54
- Synchronization Local PC button
- Alarm On (s): 2
- Alarm Off (s): 2
- Menu Block Time (s): 60
- Backlight time (s): 30
- Internal CO2 Sensor section:
 - Pre Alarm Setpoint: 2000
 - Alarm Setpoint: 2500
 - Calibrating Offset: 191
 - Clear External Calibration Offset button
- Heating humidity sensor: Enable Disable
- Relative Humidity: 61.2 %
- CO2: 857 ppm
- Alarm Setting: Manual Auto
- Alarm State: OFF
- Password: 1234 (with Enable/Disable radio buttons)
- Table:

	Name	Range	A/M	Value	Calibration
1	Tempreture	°C	Auto	13.4	
2	Hum	%	Auto	61.2	
3	CO2	ppm	Auto	857	

At the bottom of the configuration panel, there is a table with the following columns: NUM, Device ID, Serial Number, External PPM, Prepare Alarm Setpoint, Alarm Setpoint, and Calibrating Offset.

CO2-Humidity-Temp Transmitter w/ Bacnet

4). Calibrate CO2

Press up arrow to increase value while press down arrow to decrease.

ID Address: 251 Enable Change Serial Number: 79181 Date: 5/27/2013 Time: 11:08

Firmware Version: 3.3 Hardware Version: 22 Braudrate: 19200

Relative Humidity: 63.7 % CO2: 988 ppm

Internal CO2 Sensor:
Pre Alarm Setpoint: 2000
Alarm Setpoint: 2500
Calibrating Offset: 192
Clear External Calibration Offset

Heating humidity sensor:
Enable Disable

Alarm Setting:
 Manual Auto
Alarm State: OFF

Password:
 Enable Disable
1234

	Name	Range	A/M	Value	Calibration
1	Tempreture	°C	Auto	13.1	
2	Hum	%	Auto	63.7	
3	CO2	ppm	Auto	988	

NUM Device ID Serial Number External PPM Prepare Alarm Setpoint Alarm Setpoint Calibrating Offset

Click

CO2-Humidity-Temp Transmitter w/ Bacnet

5). Calibrate humidity.

ID Address Serial Number

Firmware Version
 Hardware Version
 Braudrate
 Relative Humidity %
 CO2: ppm

Alarm Setting
 Manual Auto
 Alarm State

Password
 Enable Disable

Date:
 Time:

Internal CO2 Sensor
 Pre Alarm Setpoint
 Alarm Setpoint
 Calibrating Offset

Alarm On (s)
 Alarm Off (s)
 Menu Block Time (s)
 Backlight time (s)

Heating humidity sensor
 Enable Disable

	Name	Range	A/M	Value	Calibration
1	Tempreture	°C	Auto	13.2	<input type="text"/>
2	Hum	%	Auto	63.8	<input type="text"/>
3	CO2	ppm	Auto	993	<input type="text"/>

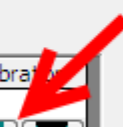
 [Click](#)

NUM	Device ID	Serial Number	External PPM	Prepare Alarm Setpoint	Alarm Setpoint	Calibrating Offset

- 19 -

CO2-Humidity-Temp Transmitter w/ Bacnet

6). Calibrate temperature.

ID Address Serial Number

Firmware Version
 Hardware Version
 Baudrate
 Relative Humidity %
 CO2: ppm

Alarm Setting
 Manual Auto
 Alarm State

Password
 Enable Disable

Date:
 Time:

 Alarm On (s)
 Alarm Off (s)
 Menu Block Time (s)
 Backlight time (s)

Internal CO2 Sensor

Pre Alarm Setpoint
 Alarm Setpoint
 Calibrating Offset

Heating humidity sensor
 Enable Disable

	Name	Range	A/M	Value	Calibration
1	Tempreture	°C	Auto	13.2	<input type="text" value="▲"/> <input type="text" value="▼"/>
2	Hum	%	Auto	63.8	<input type="text" value="▲"/> <input type="text" value="▼"/>
3	CO2	ppm	Auto	999	<input type="text" value="▲"/> <input type="text" value="▼"/>

NUM	Device ID	Serial Number	External PPM	Prepare Alarm Setpoint	Alarm Setpoint	Calibrating Offset

[Click](#)

CO2-Humidity-Temp Transmitter w/ Bacnet

5). Calibrate CO2

Graphic Viewer **Advanced Setup** Schedule LCD Help [?]

Input

	Name	Value
1	Internal Sensor	11.9 C
2	Input 1	1011
3	Input 2	1007
4	Input 3	1012
5	Input 4	1011
6	Input 5	1012
7	Input 6	1013
8	Input 7	1012
9	Input 8	1012
10	Humidity Sensor	0.0%
11	CO2 Sensor	1141ppm
12	Lighting Sensor	1 LUX

Output

	Name	Value
1	Output 1	0%
2	Output 2	0%
3	Output 3	0%
4	Output 4	Off
5	Output 5	On
6	Output 6	0.0%
7	Output 7	100.0%

Zigbee topological graph

CO2-Humidity-Temp Transmitter w/ Bacnet

Parameter

ID Address: 254 Enable Change Refresh Exit

General Setting

Baudrate: 19200 Auto Only: Input Filter: 2

Keypad Select: 4A Setpoint Increments: 1.0 Powerup Setpoint: 20 Short Cycle Delay: 0

Powerup Mode: Last Sequence: Fan Coil Rounding display: normal Keypad Lock: Lock On

Temp Unit: °C heat/cool changeover: Auto (PID) Backlight OFF Time: 1 min

Timer

General Setting

Timer On: 0 Timer Off: 0 Units: Second Time Left: 0 min Override Period: 0 min

Timer left: Timer Select: Period timer

PIR Sensor Setting

Enable/Disable: Disable Setpoint Display: Temperature

Sensitivity: 100

Day Setpoint

Loop	Day/Occ Setting	Max	Min	Cooling Dead Band	Heating Dead Band
Loop1	10.0	50	10	1.0°C	1.0°C
Loop2	200.0			0.1	0.1
Loop3	51455			135	4

Night Setpoint

Night/Unocc Mode: Office Cooling SetPoint: 300°C Heating SetPoint: 150°C

Custom Sensor Table

Table 1

Table 2

Setpoints

	DAY	NIGHT
1 SP/2 SP:	2 SP	2 SP
COOL DB:	1	1
Setpoint:	10	21
Heat DB:	1	1
Heat SP:	9	15
COOL SP:	11	30

PID

Loop	Input select	Input value	Setpt value	Output	Pterm	Item
Loop1	HUM TEM	19.0°C	10	100%	6.0	5.0
Loop2	Internal TEM	UNUSED	200.0	44%	100.0	1.0
Loop3	Internal TEM	UNUSED	51455	50%	0.8	0.1

PID off Setpoint: 300.0

Special Features

Free cooling Outdoor Reset

Airflow Setting

Valve Travel Time: 90

Inputs Outputs Outputs Table

Click it

Setpoint Increments: 1.0 Powerup Setpoint: 20 Short Cycle Delay: 0

Mode: Default 20

Input Set Dialog

	Input Name	Value	Auto/Man	Calibration	Filter	Range	Function	Custom Tables
0	Internal Sensor	12.2°C	Auto	Adjust...		°C	N/A	N/A
1	Input 1	1012	Auto	Adjust...	3	Raw	Normal	N/A
2	Input 2	997	Auto	Adjust...	3	Raw	Normal	N/A
3	Input 3	1012	Auto	Adjust...	3	Raw		N/A
4	Input 4	1011	Auto	Adjust...	3	Raw		N/A
5	Input 5	1012	Auto	Adjust...	3	Raw		N/A
6	Input 6	1012	Auto	Adjust...	3	Raw		N/A
7	Input 7	1012	Auto	Adjust...	3	Raw		N/A
8	Input 8	1012	Auto	Adjust...	3	Raw	Normal	N/A
	Humidity Sensor	0.0%	Auto	Adjust...	3			
	CO2 Sensor	1137ppm	Auto	Adjust...	3			

Write the real value

Save Fresh Exit

CO2-Humidity-Temp Transmitter w/ Bacnet

6). Calibrate humidity

Auto Only Input Filter Occupied setpoint control Mode Default

Setpoint Increments Powerup Setpoint Short Cycle Delay

Input Set Dialog

	Input Name	Value	Auto/Man	Calibration	Filter	Range	Function	Custom Tables
0	Internal Sensor	13.0°C	Auto	Adjust...		°C	N/A	N/A
1	Input 1	1011	Auto	Adjust...	3	Raw	Normal	N/A
2	Input 2	1012	Auto	Adjust...	3	Raw	Normal	N/A
3	Input 3	1011	Auto	Adjust...	3	Raw		N/A
4	Input 4	1011	Auto	Adjust...	3	Raw		N/A
5	Input 5	1012	Auto	Adjust...	3	Raw		N/A
6	Input 6	1012	Auto	Adjust...	3	Raw		N/A
7	Input 7	1011	Auto	Adjust...	3	Raw		N/A
8	Input 8	1011	Auto	Adjust...	3	Raw	Normal	N/A
	Humidity Sensor	0.0%	Auto	Adjust...	3			
	CO2 Sensor	1392ppm	Auto	Adjust...	3			

Write the real value

Save Fresh Exit

7). Calibrate temperature.

Auto Only Input Filter Mode Default

Setpoint Increments Powerup Setpoint Short Cycle Delay

Input Set Dialog

Write the real value

	Input Name	Value	Auto/Man	Calibration	Filter	Range	Function	Custom Tables
0	Internal Sensor	13.0°C	Auto	Adjust...		°C	N/A	N/A
1	Input 1	1011	Auto	Adjust...	3	Raw	Normal	N/A
2	Input 2	1012	Auto	Adjust...	3	Raw	Normal	N/A
3	Input 3	1011	Auto	Adjust...	3	Raw		N/A
4	Input 4	1011	Auto	Adjust...	3	Raw		N/A
5	Input 5	1012	Auto	Adjust...	3	Raw		N/A
6	Input 6	1012	Auto	Adjust...	3	Raw		N/A
7	Input 7	1011	Auto	Adjust...	3	Raw		N/A
8	Input 8	1011	Auto	Adjust...	3	Raw	Normal	N/A
	Humidity Sensor	0.0%	Auto	Adjust...	3			
	CO2 Sensor	1392ppm	Auto	Adjust...	3			

Save Fresh Exit

CO2-Humidity-Temp Transmitter w/ Bacnet

CO2-N in T3000 Operation

1). Connect CO2-N to PC by RS485.



2). Open T3000 and it show the following view. Click the button to scan, the following view will appear and close it as the picture indicates.

The screenshot shows the T3000 software interface with a 'Scan Result' dialog box open. The dialog box contains a table with the following data:

Model	Building	Floor	Room	Sub_net	Serial#	Address	Port	Protocol
CO2 Node	fault_Buildi	floor1	room1	fault_Buildi	94464	3	COM29	Modbus 485
BB/LB/TB:65729-1-192.168.0.	fault_Buildi	floor1	room1	fault_Buildi	65729	192.168.0.109	10000	TCP/IP
BB/LB/TB:90023-1-192.168.0.	fault_Buildi	floor1	room1	fault_Buildi	90023	192.168.0.15	502	TCP/IP
BB/LB/TB:92294-1-192.168.0.	fault_Buildi	floor1	room1	fault_Buildi	92294	192.168.0.97	502	TCP/IP
3-221:94216-254-192.168.0.2	fault_Buildi	floor1	room1	fault_Buildi	94216	192.168.0.29	502	TCP/IP
J8AO6DO:95238-254-192.16.	fault_Buildi	floor1	room1	fault_Buildi	95238	192.168.0.98	502	TCP/IP
BB/LB/TB:96892-254-192.168	fault_Buildi	floor1	room1	fault_Buildi	96892	192.168.0.3	502	TCP/IP
BB/LB/TB:65550-1-192.168.0.	fault_Buildi	floor1	room1	fault_Buildi	65550	192.168.0.14	502	TCP/IP
IF1:33685761-248-192.168.0.	fault_Buildi	floor1	room1	fault_Buildi	33685761	192.168.0.14	502	TCP/IP
B/LB/TB:65569-254-192.168.0.	fault_Buildi	floor1	room1	fault_Buildi	65569	192.168.0.109	502	TCP/IP

CO2-Humidity-Temp Transmitter w/ Bacnet

3). The following view shows Background calibration for CO2-N added.

The screenshot displays the T3000 Building Automation System interface. The left sidebar shows a tree view of the 'Default_Building' with a 'CO2-N' node highlighted under 'Serial Port'. The main window shows the configuration for this node, including ID Address (3), Serial Number (94464), and Firmware Version (3.9). The 'CO2 Automatic Compensation Background' settings are highlighted with a red box and labeled 'added'. The settings are:

- CO2 Automatic Compensation Background: OFF
- Background CO2: 400 ppm
- Number of days of watch for minimum: 7 days
- Maximum adjustment per day: 1 ppm

The 'CO2 Alarms' section shows 'Poor >' at 800 and 'Fair >' at 1000. Below the settings are two tables:

INPUT Setting	
NUM	Full Label
1	Tempreture
2	Hum
3	CO2

OUTPUT Setting				
NUM	Full Label	Range	Min Out Scale	Max Out Scale
1	Tempreture	0-10v	0	1000
2	Hum	0-10v	0	1000
3	CO2	0-10v	0	2000

CO2-Humidity-Temp Transmitter w/ Bacnet

3). You can use the t3000 to set the configuration. The following view shows how to set up the span of the analog outputs.

1. We have a jumper on the background of the PCB, you can set it to 0~10V, 0~5V or 4~20mA.

2. Set the range. For example, if the temperature is 20.0 c, the range you set the min out scale 0, the max out scale 1000(100.0 degree c), then the output = $20.0 / (100.0 - 0.0) * 10V = 2V$.

INPUT Setting

NUM	Full Label	Value	Range	Calibra...
1	Tempreture	0.0	°C	UNUSED
2	Hum	0.0	%	UNUSED
3	CO2	392	ppm	5

OUTPUT Setting

NUM	Full Label	Range	Min Out Scale	Max Out Scale	Unit
1	Tempreture	0-10v	0.0	100.0	°C
2	Hum	0-10v	0.0	100.0	%
3	CO2	0-10v	0.0	2000.0	ppm

CO2-Humidity-Temp Transmitter w/ Bacnet

3. Also, you can use the modbus poll to configure it.

127	1	analog output mode, change it by setting the jumper (J20) on the board, read only
128	2	the minimum value of temperature directs to the analog output
129	2	the maximum value of temperature directs to the analog output
130	2	the minimum value of humidity directs to the analog output
131	2	the maximum value of humidity directs to the analog output
132	2	the minimum value of co2 directs to the analog output
133	2	the maximum value of co2 directs to the analog output
		e.g. co2 output: if the co2 ppm is 1000, the (minimum value, maximum value) = (0, 3000), then
		1. setting J20 to select 0V-10V output mode, so the co2 output is about $((1000\text{ppm} / (3000\text{ppm} - 0\text{ppm})) * (10\text{V} - 0\text{V})) + 0\text{V} = 3.3\text{V}$
		2. setting J20 to select 0V-5V output mode, so the co2 output is about $((1000\text{ppm} / (3000\text{ppm} - 0\text{ppm})) * (5\text{V} - 0\text{V})) + 0\text{V} = 1.65\text{V}$
		3. setting J20 to select 4mA-20mA output mode, so the co2 output is about $((1000\text{ppm} / (3000\text{ppm} - 0\text{ppm})) * (20\text{mA} - 4\text{mA})) + 4\text{mA} = 9.3\text{mA}$

CO2-Humidity-Temp Transmitter w/ Bacnet

Connecting to the device using Bacnet

The device can be connected using Bacnet. Below are the steps:

Step 1. Download Yabe software as the link: <https://tinyurl.com/ycrt9jep> and install it.

Step 2. Connect the device to the computer, select Bacnet protocol. Start the Yabe software, add the device.

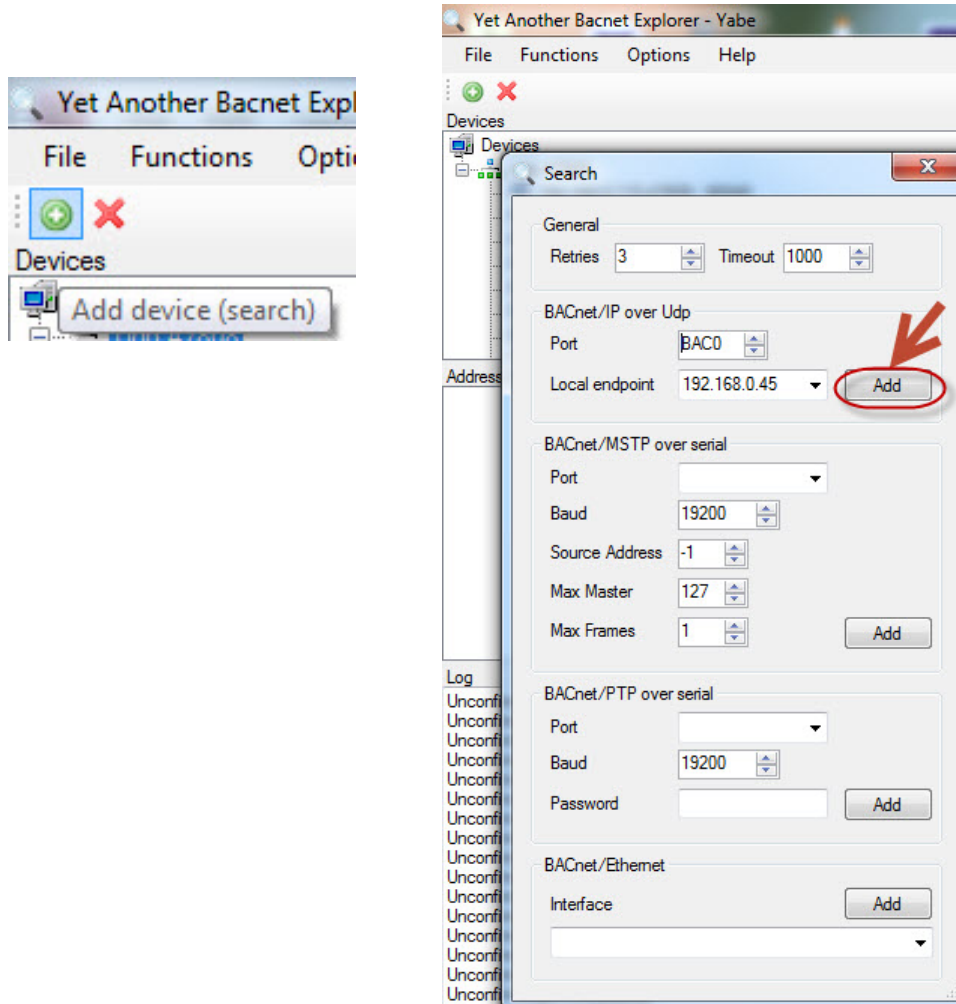

Step 3. You can find your device IP as below. Double click the left mouse button, you can find your device and the bacnet information in the "Address Space" tab.

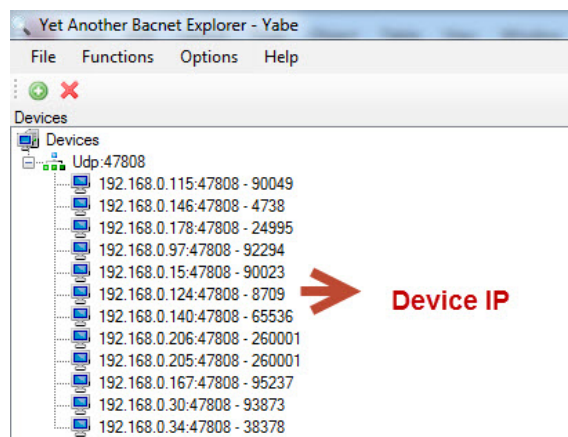

CO2-Humidity-Temp Transmitter w/ Bacnet

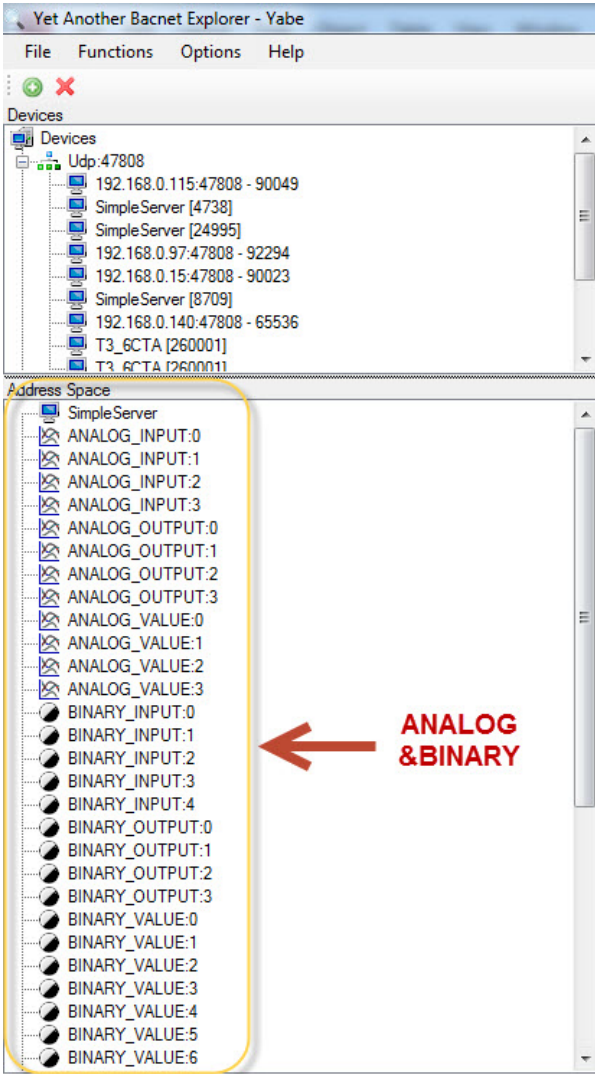

Step4. In the "Address Space" tab, click the "ANALOG_VALUE", it will show the information of "log ANALOG_VALUE" in the BacnetProperty tab. And it's the same with "ANALOG_OUTPUT" and other items.

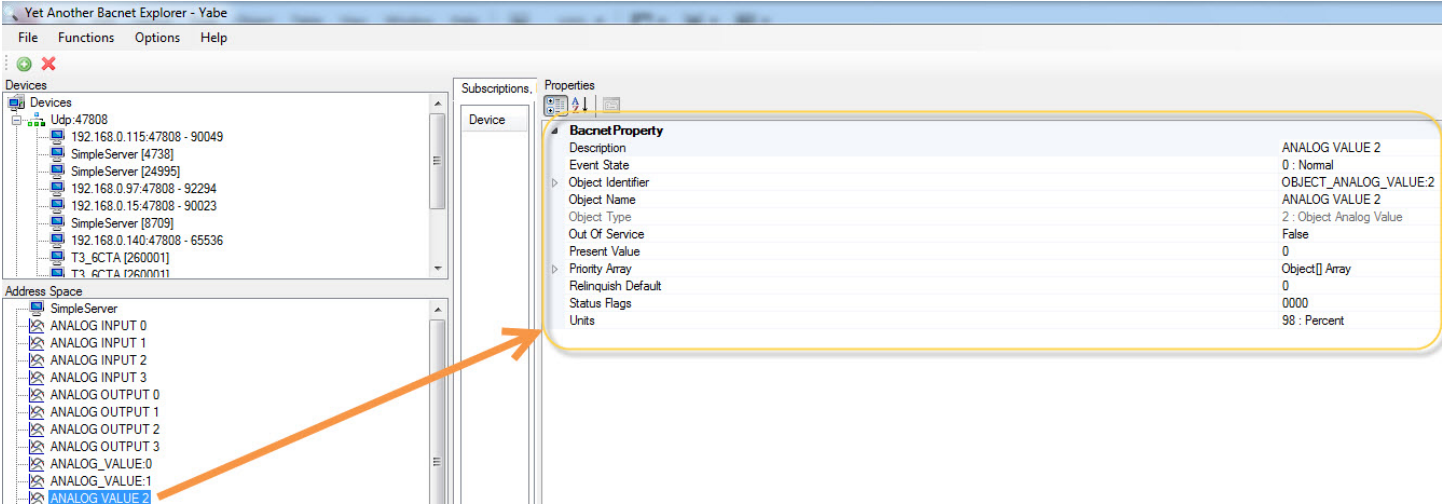

CO2-Humidity-Temp Transmitter w/ Bacnet

Address	Bytes	CO2-D1&CO2-W1 Without Ethernet Register Description
0..1	2	Lower 2 bytes of the serial number
2..3	2	Upper 2 bytes of the serial number
4	1	firmware version lower byte. eg. FW version = 10.12, so lower byte = 12 AND high byte = 10. Fixed.
5	1	firmware version upper byte. eg. FW version = 10.12, so lower byte = 12 AND high byte = 10. Fixed.
6	1	Default Modbus device address=254
7	1	Product ID, Fixed.
8	1	Hardware version
9	1	spare
10	1	spare
11	1	Time zone
12	1	Baudrate Setting: 0 = 9600bps, 1 = 19200bps,2=38400bps,3=57600bps,4=115200bps
13	1	day lighting switch, 0 =disable day lighting feature, 1= enable
14	1	spare
15	1	reset flash. The unit will clear all configs to zero if this register being set to 0x55 = 85
16	1	Firmware Update Register, used to show the status of firmware updates
17 to 20	4	spare
21	1	Protocol switch. 3 = MODBUS,0=MSTP.
22~39	18	spare
40 to 45	6	reg40, MAC address, read only normally. (they can be written if write the regsiter 93 to 1 first, for the default setting before out of the factory.)
46	1	reg46, IP mode. 0=static IP; 1= DHCP
47 to 48	2	reg47, upper two bytes of IP address
49 to 50	2	reg49, lower two bytes of IP address
51 to 52	2	reg51, right two bytes of SUBNET MASK address
53 to 54	2	reg53, left two bytes of SUBNET MASK address
55 to 56	2	reg55, right two bytes of GATEWAY address
57 to 58	2	reg57, left two bytes of GATEWAY address
59	1	reg59, 0, TCP server, (NO USE)
60	1	reg60, listen port at TCP server mode
61 to 75		buffer mirror for changing to a new IP address, copy of reg 46 to 60
76	1	write 1 to set the ghost settings to the system and start new settings, then clear the ghost registers.
91	1	Set 1 manual to write configurations to flash
92	1	Period of write configurations to flash if configurations changed without setting register to 1. counter by second.
93	1	Enable for MAC setting. It should be set as 1 before write the new MAC to the MAC registers(100-105), and it will be cleared automatically after setting the MAC address.
94 to 99	7	Reserved for future.
100 to 105	6	reg100, MAC address, read only normally. (they can be written if write the regsiter 93 to 1 first, for the default setting before out of the factory.)
106	1	reg106, IP mode. 0=static IP; 1= DHCP

CO2-Humidity-Temp Transmitter w/ Bacnet

Address	Bytes	CO2-D1&CO2-W1 Without Ethernet Register Description
111 to 112	2	reg111, right two bytes of SUBNET MASK address
113 to 114	2	reg113, left two bytes of SUBNET MASK address
115 to 116	2	reg115, right two bytes of GATEWAY address
117 to 118	2	reg117, left two bytes of GATEWAY address
119	1	reg119, 0, TCP server, (NO USE)
120	1	reg120, listen port at TCP server mode
121 to 135	1	buffer mirror for changing to a new IP address, copy of reg 106 to 120
136	1	write 1 to set the ghost settings to the system and start new settings, then clear the ghost registers.
137 to 171	40	Reserved
172	1	scan command< =6 start scan>/LHN add
173	1	subnet <add =1rs485 =2zigbee =4all> /LHN add
174	1	NTP command< =6,start ntp >/LHN add
175 to 178	4	Time Server0 ipaddress
179 to 182	4	Time Server1 ipaddress
183 to 186	4	Time Server2 ipaddress
187 to 190	4	Time Server3 ipaddress
191 to 194	4	Time Server4 ipaddress
195 to 198	4	Time Server5 ipaddress
199	1	Time Sync result: 0-Fail 1-Successful
200	1	Temperature sensor selection, 0=external, 1=internal. Read only, it will be set to 1 if the humidity module exists.
201	1	Select the unit of temperature to display on LCD. 0=degree Celsius, 1=degree Fahrenheit
202	2	The value of on board temperature sensor, the unit is degree Celsius. The resolution is 0.1 degree.
203	2	The value of on board temperature sensor, the unit is degree Fahrenheit. The resolution is 0.1 degree.
204	2	The value of external temperature sensor, the unit is degree Celsius. The resolution is 0.1 degree.
205	2	The value of external temperature sensor, the unit is degree Fahrenheit. The resolution is 0.1 degree.
206	2	The temperature offset for calibrating the internal temperature. The resolution is 0.1 degree.
207	2	Relative humidity. The resolution is 0.1%
208	2	Read only. The real frequency read from the humidity module, unuse.
209	1	Read only. The number of the calibration table points.
210	1	Internal CO2 sensor selection. The value is 1 as default.
211	2	The co2 ppm value of internal co2 sensor.
212	2	The co2 ppm offset for calibrating internal co2 sensor.
213	2	The setpoint value of fair alarm for internal co2 sensor.
214	2	The setpoint value of poor alarm for internal co2 sensor.
215 to 468	2*254	The co2 ppm value of the external co2 sensors if there are/is co2 nodes connect to it.
469 to 722	2*254	The co2 ppm offset for calibrating external co2 sensors.
723 to 976	2*254	The setpoint value of fair alarm for external co2 sensors.